

8' CONCRETE WHEEL STOP
NO SCALE

NOTE TO DESIGNER:
DRAIN TYPE 8'. 10" WIDE, 6" HIGH. TWO 3/8" REINFORCEMENT RODS. TWO 1/16"x15" HOLDER PINS WEIGHT 300 LBS.

SUPPLIERS:
1. AMERICAN EAGLE
313-444-8391
SALES@AMERICANEAGLEPRECAST.COM
2. BUSH CONC. PRODUCTS
231-733-1904
INFO@BUSHCONCRETEPRODUCTS.COM
3. OR APPROVED EQUAL

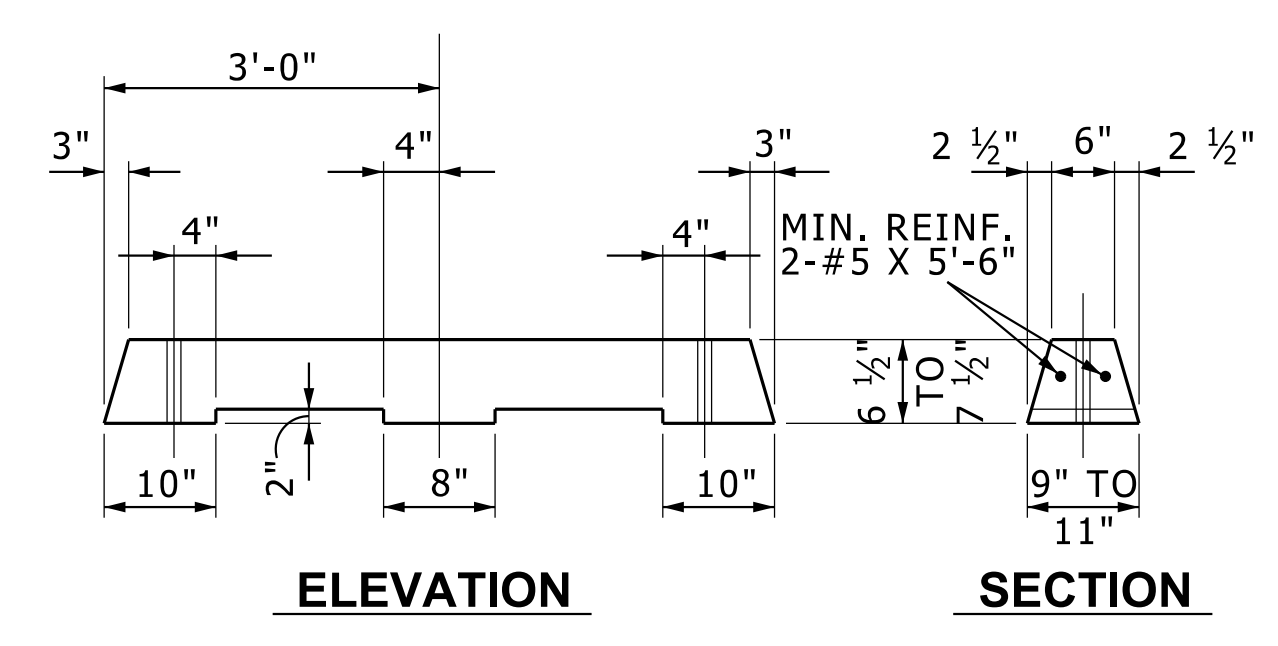
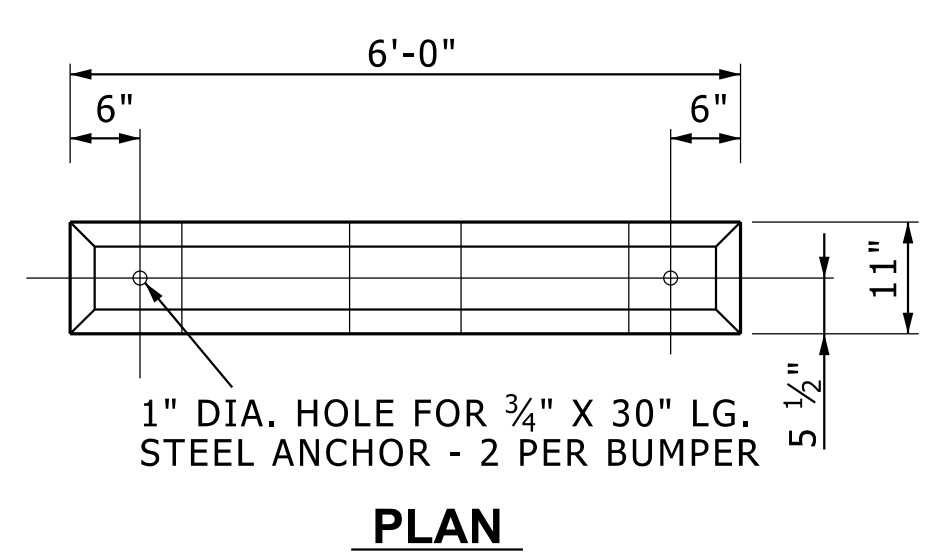

6' CONCRETE WHEEL STOP
NO SCALE SECTION, ELEVATION, PLAN

SD-MISC-WHEEL_STOPS