

NOTE:

1. SUPPORT PIPING SO THAT THERE IS NO WEIGHT ON PUMP.
2. PROVIDE INERTIA BASE WHEN REQUIRED BY SPECIFICATION, OTHER DETAILS OR SCHEDULES.

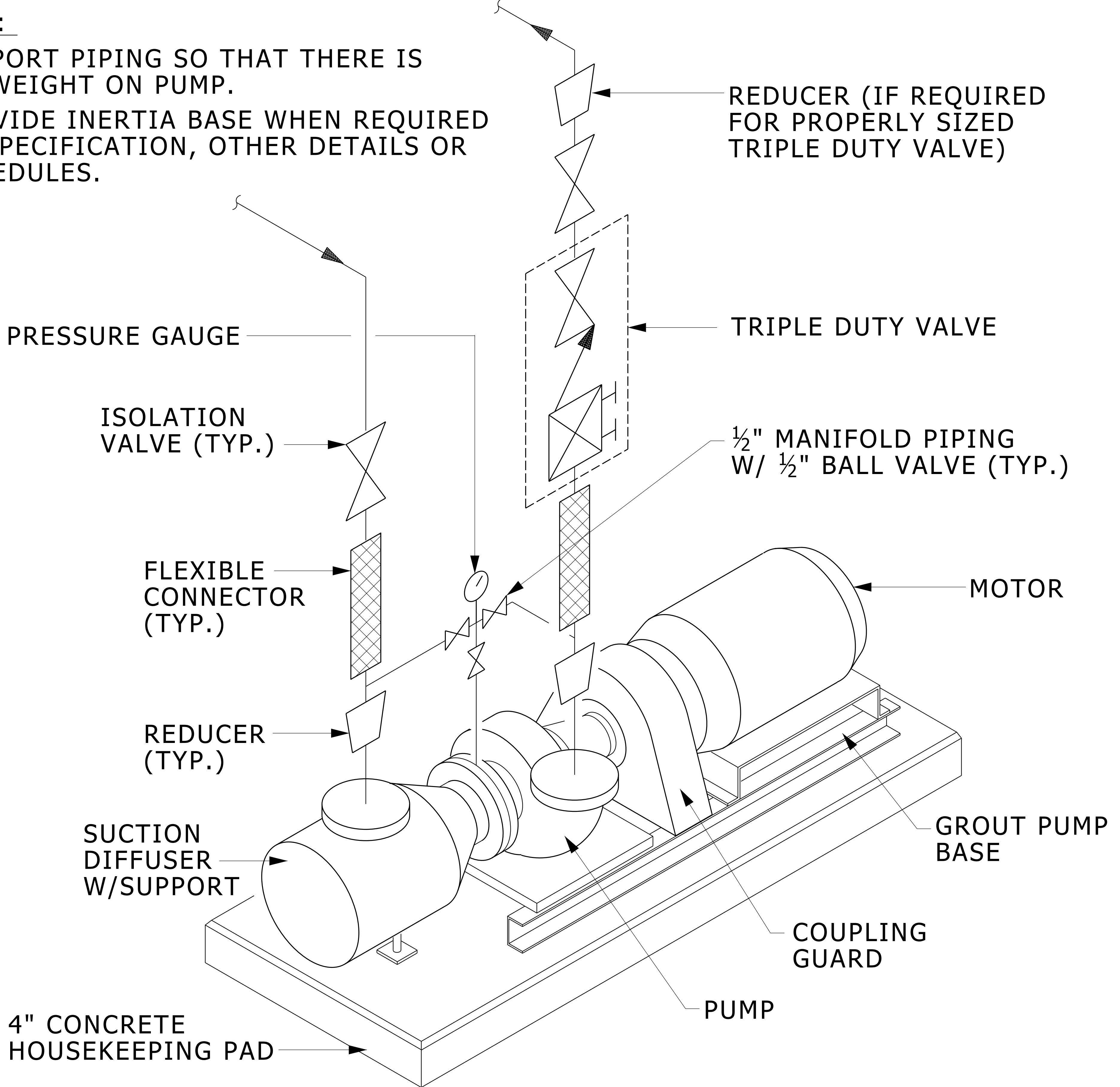

END SUCTION PUMP INSTALLATION

NO SCALE

MD 232123 001 2024-09-01

DESIGNER NOTES:

SELECT EITHER A TRIPLE DUTY VALVE OR A COMBINATION OF MANUAL BALANCING VALVE AND CHECK VALVE AT THE PUMP DISCHARGE. UPDATE THE DETAIL ACCORDINGLY. FOR PUMPS WITH VFD'S OR ECM'S, THE TRIPLE DUTY VALVE OR BALANCING VALVE IS PRIMARILY INTENDED FOR FLOW MEASUREMENT DURING TAB. NOTE ON THE DRAWING THAT THESE VALVES MUST BE KEPT FULLY OPEN ONCE THE TAB IS COMPLETE. THROTTLED VALVES AT THE PUMPS ARE NOT PERMITTED.

